



GR



Mantovanibenne s.r.l. - Mirandola (Mo) Italy - Tel. +39 0535 615811 - Fax +39 0535 615830
sales@mantovanibenne.com

RIE-97876/E-07/11 Rev.00
Caratteristiche di prodotto e specifiche possono variare senza obbligo di preavviso.
Les caractéristiques et les spécifications des produits peuvent être modifiées sans préavis.

GR Demolition Grapple

The new range of the GR Demolition Grapples comes from the experience of Mantovanibenne. This line of attachments with its attractive design is characterised by the latest technology. The GR Demolition Grapples have been designed and manufactured for the demolition of structures: in brick, wood and other materials as well as for the selection of demolition debris making recycling more feasible. They can also be widely used for the selection and handling of waste.

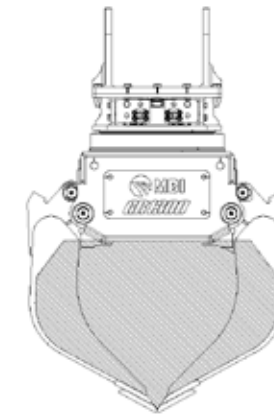
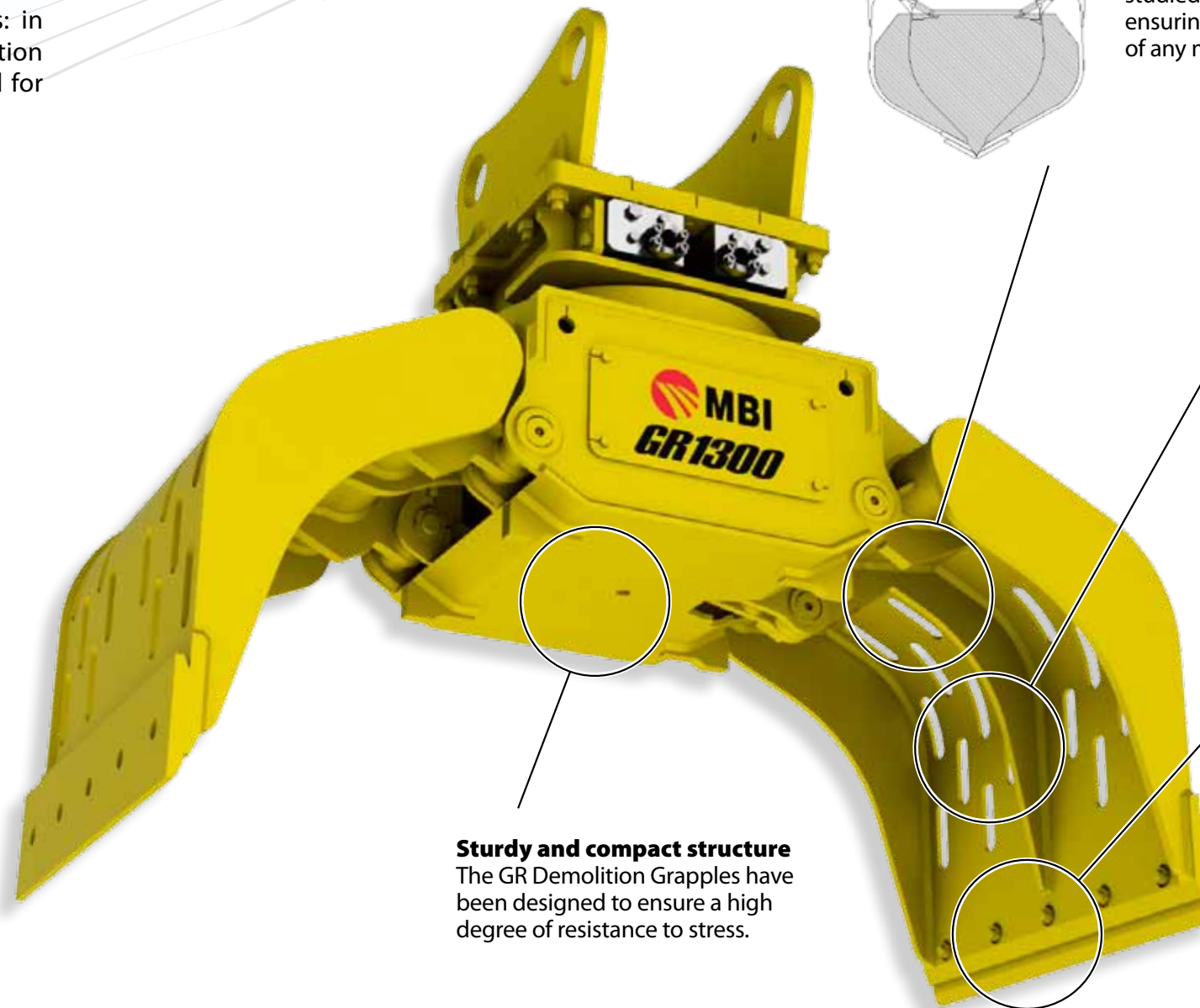
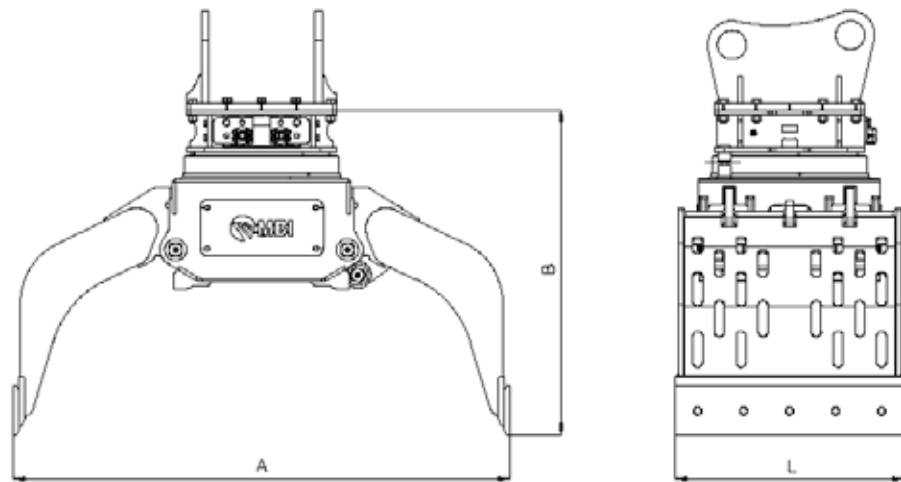

High Capacity

The particular design of the jaws was studied to obtain a high capacity ensuring high production of any material and any type of work.

Anti-wear material

The GR Demolition Grapples are built with high wear resistant materials with a hardness of HB 400.

Blades

Each GR Demolition Grapple is supplied with reversible blades. The correct maintenance of these parts allows a high degree of accuracy in handling operations.

Sturdy and compact structure

The GR Demolition Grapples have been designed to ensure a high degree of resistance to stress.

We are constantly improving our products and therefore we reserve the right to change the design and technical specifications without prior notice.

TECHNICAL SPECIFICATIONS													
MODEL		GR150	GR300	GR500	GR600	GR850	GR1000	GR1200	GR1300	GR1500	GR2200	GR2400	GR3400**
Excavator Weight	t	2-3,5	3-6	5-8	7-10	11-15	13-18	16-21	16-21	22-27	28-34	30-45	45-70
Tool weight *	kg	150	320	535	595	850	950	1300	1400	1500	2200	2400	3900
Opening A	mm	960	1200	1570	1570	1710	1825	2040	2040	2110	2300	2500	2700
Height with open GR B	mm	665	900	990	990	1060	1090	1350	1350	1370	1870	1930	1835
Width L	mm	400	500	600	750	750	850	700	950	1100	1130	1300	1400
Hydraulic working pressure	bar	200-250	200-250	200-250	200-250	280-320	280-320	280-320	280-320	280-320	280-320	280-320	280-320
Oil flow	l/min	10-15	20-30	20-30	20-30	50-60	50-60	50-60	50-60	50-60	80-90	80-90	100-150

RIF. 97886/E

**New model available soon.

*Tool weight does include Mantovanibenne top bracket.

