

TENSIONING POWER TRANSMISSION BELTS

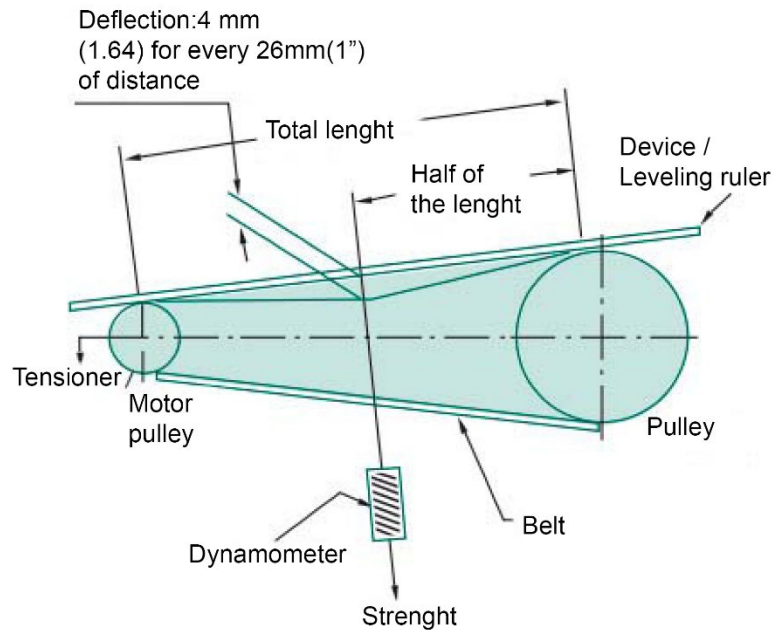

What is the correct procedure for tensioning power transmission belts?

Correct tensioning of transmission belts undoubtedly brings many benefits and avoids various inconveniences.

We must always remember some basic rules:

- The ideal tension is the minimum possible, without the belt slipping or "skidding" on the pulley, considering the conditions when the equipment is subjected to the highest torque
- Excessive tension decreases the service life of belts, bearings/bushings and can cause internal damage to the engine/equipment; on the other hand, low voltage will cause slippage, generating excessive heat in the belts and causing premature failure;
- After changing belts, check the tension of the belts in the first 48 hours of operation
- Perform periodic inspections on the transmission assembly, properly tensioning the belts when necessary
- For uniform tensioning on the belts, it is recommended not to mix different brands, install sets with diameters/lengths of the same series and not to use new belts together with old belts.
- Using equipment with one or more belts missing for extended periods of time may differentiate pulley channel wear and tensioning will not be ideal after belt assembly replacement.

Initial tension control

Once the initial belt stress suitable for the load to be transmitted has been calculated, the value of this tension must be oriented from a control of the belt deformation under a force applied perpendicularly in the middle of the branch, as shown in fig. 4. This control method is recommended for the adjustment of the initial tension on V-belts with a width of up to 22 mm (C or SPC profiles) and is known as the deflection method.

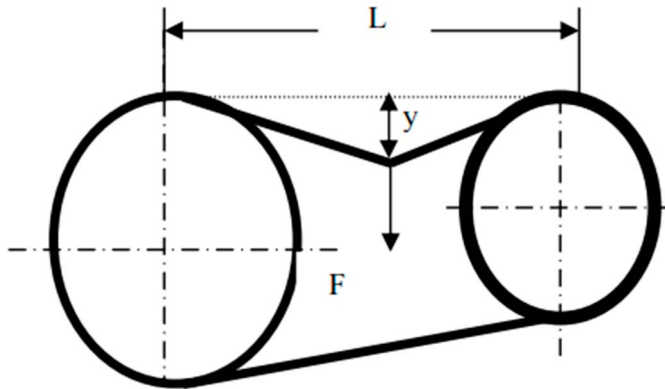

Fig. 1. Control of initial tension. Deflection method.

Deflection Method

This method recommends controlling the initial tension of the belt by taking as a reference the value of the control force "F", which causes a constant "y" deflection, as can be seen in Figure 1. It is a procedure that is convenient to apply when a dynamometer is available for control. A constant deflection of 16 mm per meter of "L" length of the branch line is generally oriented.

$$y = \frac{16}{1000} \cdot L \quad [\text{mm}]$$

By performing a static analysis of the branch where the initial assembly tension control is carried out, the control force "F" can be determined, applied perpendicular to the belt in the middle of the branch and causing a deflection "y", according to the following table:

Section Belt	Smaller pulley diameter	Belt force used (N) (Kgf)			
SPZ XPZ	56 to 71	16	1.6	20	2.0
	75 to 90	18	1.8	22	2.2
	95 to 125	20	2.0	25	2.5
	> 125	22	2.2	28	2.8
SPA XPA	80 to 100	22	2.2	28	2.8
	106 to 140	30	3.0	38	3.8
	150 to 200	36	3.7	45	4.6
	> 200	40	4.0	50	5.1
SPB XPB	112 to 160	40	4.0	50	5.1
	170 to 225	50	5.1	62	6.3
	236 to 355	62	6.3	77	7.9
	> 355	65	6.6	81	8.3
SPC	225 to 250	70	7.1	87	8.9
	265 to 375	92	9.4	115	12.0
	> 375	115	12.0	144	15.0
8V	>= 335	150	15.0	190	19.0
Z	56 to 100	5 a 75	0.5 a 1.5		
A / AX	80 to 140	10 a 15	1.0 a 1.5		
B / BX	125 to 200	20 a 30	2.0 a 3.1		
C	200 to 400	40 a 60	4.1 a 6.1		
D	355 to 600	70 a 105	7.1 a 10.7		

➤ **What should be taken into account when selecting a belt?**
The most important parameters to take into account for the selection of the most suitable belt are the following:

- Transmission Torque
- Rotation speed
- Wheelbase
- Reduction ratio
- Temperature and lubrication conditions

➤ **What happens if the belt is very tight?**
Excessive stress decreases the life of bearing/bushing belts and can cause internal damage to the engine/equipment

➤ **What if the belt is not taut enough?**
Low tension will cause slippage generating excessive heat in the belts and causing premature failure.